

# PENTAX®

## REAR CONVERTER A

1.4X-S, 2X-S, 1.4X-L, 2X-L

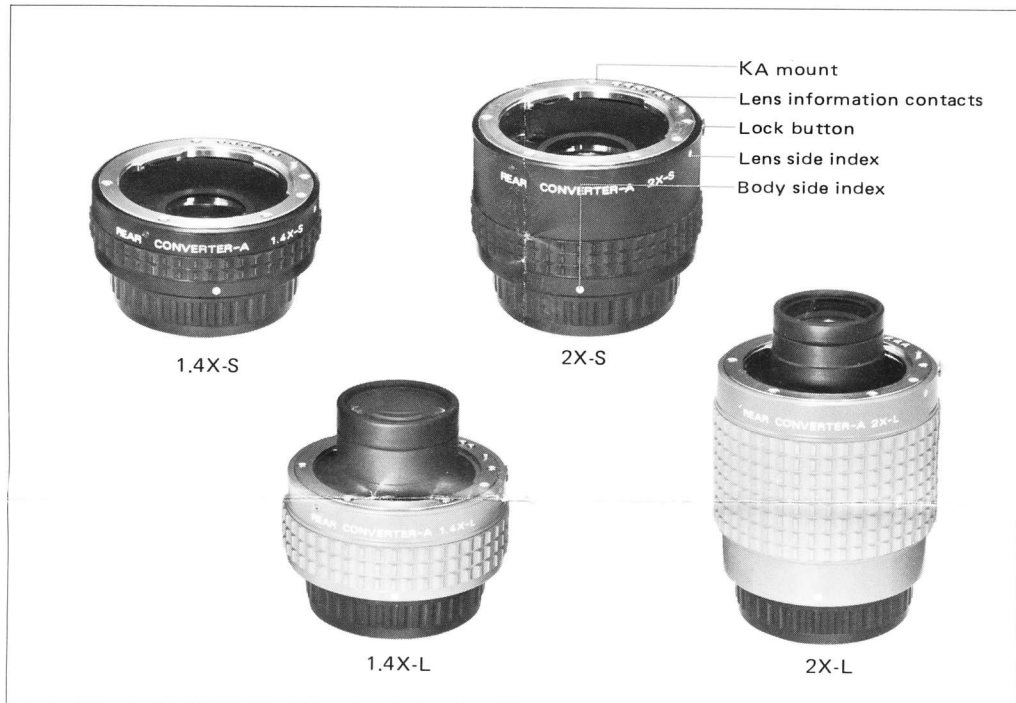

The Pentax Rear Converter A, available in four variations, 1.4X-S\*, 2X-S, 1.4X-L\* and 2X-L, is a new convenient teleconverter accessory, which, when mounted between Pentax 35mm SLR body and any compatible lens, allows 1.4X increase (w/1.4X-S or -L) or doubling (w/2X-S or -L) of the focal length and the set f/number of the master lens in use.

As the Rear Converter A is provided with electrical contacts capable of receiving information signals from the "A" lens, its combination with Pentax KA mount camera + SMC Pentax A lens permits a full use of various photographing modes including Programmed AE control. Meanwhile, when combined with Pentax K (Kf) mount body and corresponding lens, open-aperture light metering and automatic aperture coupling can be used, further, the exposure value can be measured by the built-in thru-the-lens exposure meter, respectively without any adjustment.

The S series converters are usable on almost all Pentax bayonet mount lenses. The L series converters are designed for telephoto lenses and ED-type ultra-telephotos. For further details, please refer to the Table on the next page.

### Obtainable focal length & f/number using Rear Converter A:

$$(1.4X-S) + (85\text{mm } f/1.4) = (119\text{mm } f/2)$$

$$(2X-S) + (200\text{mm } f/4) = (400\text{mm } f/8)$$

$$(1.4X-L) + (300\text{mm } f/2.8) = (420\text{mm } f/4)$$

$$(2X-L) + (300\text{mm } f/2.8) = (600\text{mm } f/5.6)$$

**Specifications**

Models	1.4X-S	2X-S	1.4X-L	2X-L
Magnification	1.4X	2X	1.4X	2X
Lens Structure (Group-Element)	4-5	6-7	5-5	5-6
Size (mm)	64.5 x 21.5	64.5 x 39	65.5 x 28.5	65.5 x 63
Weight (g/oz.)	145/5.1	210/7.4	175/6.2	255/9.0
Coating	SMC Coating			
Diaphragm/Light Metering	Automatic Diaphragm · Open-Aperture Light Metering			
Mount	Pentax KA Mount (with electric contacts)			
Usable Lenses	SMC Pentax lenses (A or M) *See the Table below.			

- Except the following lenses, all currently available Pentax lenses can be used with 1.4X-S and 2X-S.

Reasons why not usable	1.4X-S	2X-S
Vignetting at each corner	A 400mm f/5.6 500mm f/4.5 A* 600mm f/5.6 ED (IF) 1000mm f/8 Reflex 1000mm f/11 Reflex 2000mm f/13.5 Zoom 135-600mm f/6.7	
Coupling Impossible	A 15mm f/3.5 15mm f/3.5 18mm f/3.5 M Zoom 24-35mm f/3.5	A 15mm f/3.5 15mm f/3.5 M Zoom 24-35mm f/3.5

- The following lenses can be used with 1.4-L and 2X-L (None of other lenses can be coupled).

1.4X-L	2X-L	Remarks
A* 300mm f/2.8 ED (IF) A* 600mm f/5.6 ED (IF)	A* 300mm f/2.8 ED (IF) A* 600mm f/5.6 ED (IF)	High optical performance obtained when combined with these lenses
A 400mm f/5.6 500mm f/4.5 1000mm f/8	A 400mm f/5.6 M 400mm f/5.6 500mm f/4.5 1000mm f/8 Zoom 135-600mm f/6.7	

**IMPORTANT:** Never combine the lens and the rear converter which cannot be coupled, to avoid possible damages.

#### Mounting Rear Converter A

(Applicable to all available types)

1. Remove the lens from your camera.  
Take off the mount cap from the Rear Converter, and attach the Rear Converter to the camera body in the same way as the lens mounting procedure.

2. Likewise, mount your lens on the Rear Converter.  
When you combine this converter with a large-sized lens, it may be convenient to first attach the converter to your lens and then to mount the lens/converter combination to your camera.

3. To remove the lens, rotate it counterclockwise while pressing the converter lock button in the direction of the arrow. A slight rotation will release the lock button. It is unnecessary to hold it all the way. Rotate the lens to the left (by  $65^\circ$ ) as far as it will go, and remove the lens.

※ As illustrated in the picture on the right, to remove a large-sized lens and Rear Converter, hold and rotate them together (lens/converter) to the left, while pressing the lock button. To remove the Rear Converter from the lens, use the same procedure as when removing the lens from camera body.

**Caution:** Always keep the lens information contacts on the lens mount of the Rear Converter free from scratch or dirt. When they get dirty, wipe off with clean, dry cloth.

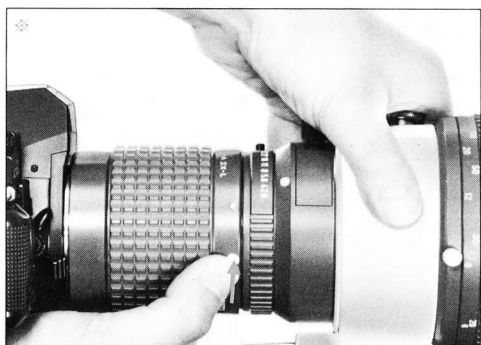



#### Precautions in Actual Use

1. With use of this converter, the focal length of your lens becomes 1.4X (1.4X-S, -L) or 2X (2X-S, -L), while the actual lens speed will be slower by one or two stops. Care should be taken when determining the exposure. We recommend using high speed film.
2. You will get better results with the aperture stopped down one or two stops. Particularly when you use a lens with a maximum aperture larger than f/2.8, we recommend stopping down to f/2.8 or more to obtain maximum performance.
3. Even when shooting landscapes with the focusing ring set at infinity ( $\infty$ ), be sure to check the focus through the viewfinder before taking pictures.
4. When the 1.4X rear converter is used, the depth of field becomes shallower by one f/stop, while it becomes shallower by two f/stops when the 2X rear converter is used. So, for example, when the 1.4X rear converter is used with the lens aperture set at f/8, the depth of field becomes as shallow as that of f/5.6.
5. The distance scale of your lens is still valid while using the Rear Converter.

6. Should the Rear Converter darken the split-image or microprism area in the viewfinder, and make it difficult to focus, we recommend focusing on the subject through the finder's matte field.
7. Since they are not designed to be stacked, more than two Rear Converter units cannot be used at the same time. Be sure to attach only one converter.
8. When the rear converter is used between an A lens and a KA mount camera, the LCD aperture information in the camera viewfinder shows that of the master lens. However, proper exposure is obtained on the resulting photographs.
9. When a Pentax dedicated auto flash unit is used in the external metering auto mode, the aperture should be opened one stop more than the designated f/number for the 1.4X-S and -L, and two stops for the 2X-S and -L. The external metering auto mode doesn't work if the aperture ring of SMC Pentax A lens is set to the "A" (auto) position. Select an appropriate f/number by releasing the ring from the locked "A" position.

#### Using the Rear Converter A for Close-up Photography.

The rear converters are capable of increasing the magnification of your lenses, but not designed for close-up photography. The great advantage of Rear Converter is the fact that lens/converter combination enables you to take photographs of objects that would otherwise be difficult to get near.



Asahi Optical Co., Ltd. C.P.O. 895, Tokyo 100-91, JAPAN  
 Pentax Europe n.v. Weiveldlaan 3-5, 1930 Zaventem, Zuid-7, BELGIUM  
 Pentax Handelsgesellschaft mbH Postfach 54 0169, 2000 Hamburg 54, WEST GERMANY  
 Pentax U.K. Limited Pentax House, South Hill Avenue, South Harrow, Middlesex HA2 0LT, U.K.  
 Pentax France S.A. Z.I. Argenteuil, 12, Rue Ambroise-Croizat, 95100 Argenteuil, FRANCE  
 Pentax (Schweiz) AG Industriestrasse 2, 8305 Dietlikon ZH, SWITZERLAND  
 Pentax Svenska AB Box 650, S-751 27 Uppsala, SWEDEN  
 Pentax Nederland Spineveld 25, 4815 HR Breda, THE NETHERLANDS  
 Pentax Corporation 35 Inverness Drive East, Englewood, Colorado 80112, U.S.A.  
 Pentax Canada Inc. 1760 West 3rd Avenue, Vancouver, B.C. V6J 1K5, CANADA  
 Asahi Optical Brasileira Ind. e Com. Ltda. Rua Capitão Antonio Rosa 376, Sala 121 Ed. PBK, São Paulo, BRASIL