

# TAMRON®

## **SP AF 70-200 mm F/2.8 DiLD [IF] Macro (Model A001)**



Thank you for purchasing the Tamron lens as the latest addition to your photographic equipment. Before using your new lens, please read the contents of this Owner's Manual thoroughly to familiarize yourself with your lens and the proper techniques for creating the highest quality images possible. With proper handling and care, your Tamron lens will give you many years of photographing beautiful and exciting pictures.

1

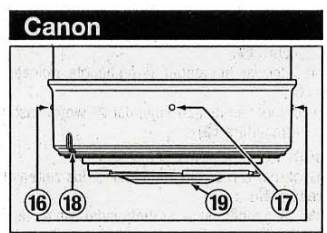
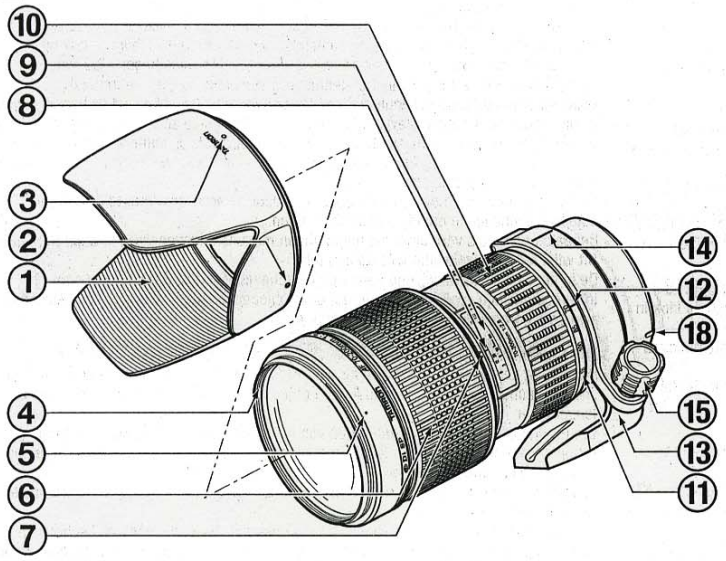

2

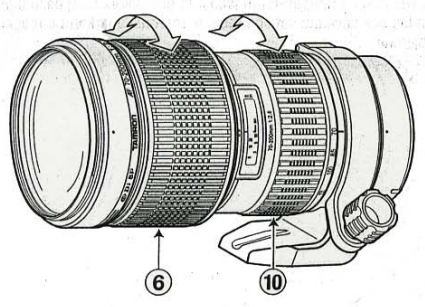

3

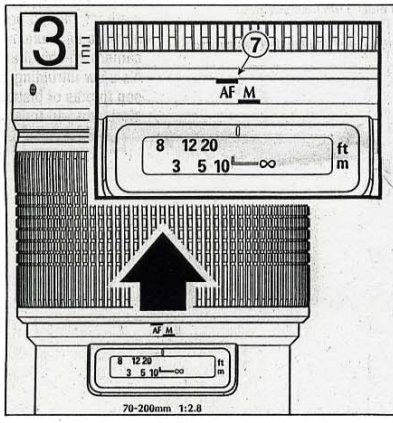

4

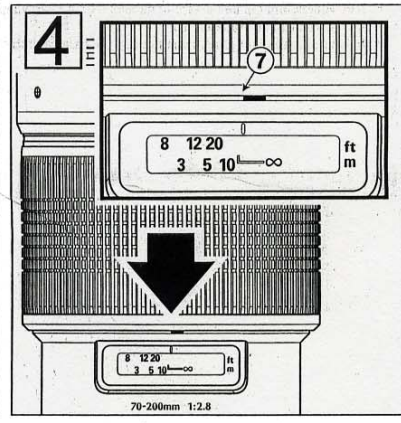

5

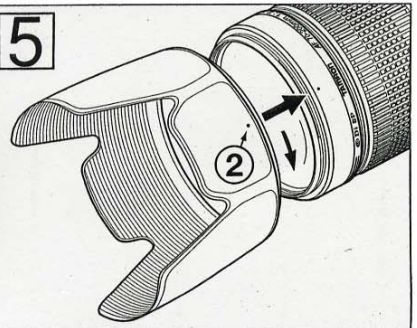

6

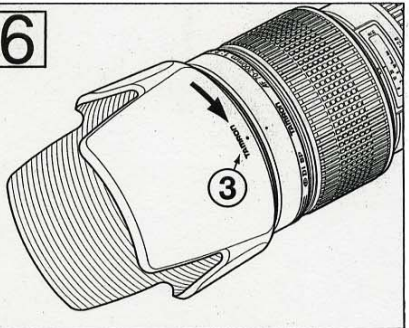

7

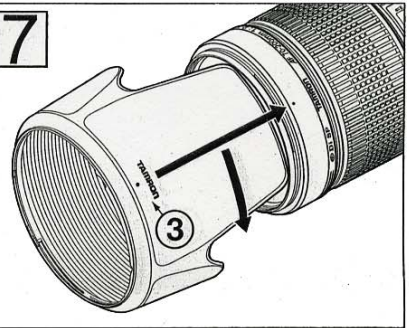

8

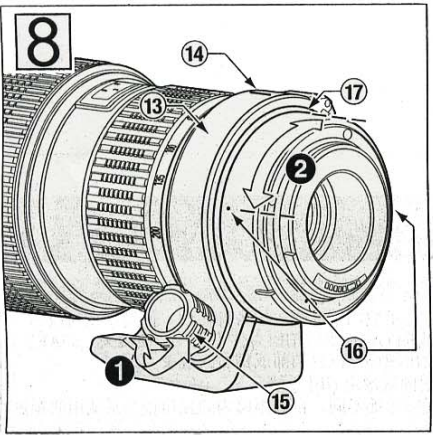

9

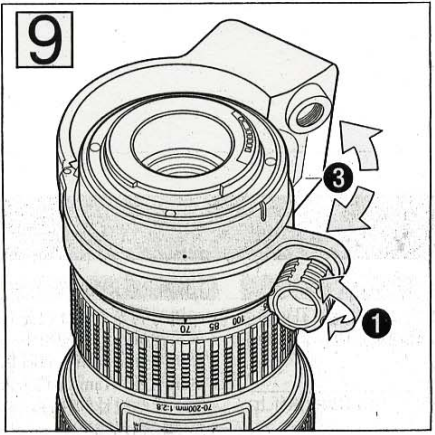

SP AF70-200mm F/2.8 Di LD [IF] MACRO (Model A001)

Focal Length	Focus Distance	F/2.8	F/4	F/5.6	F/8	F/11	F/16	F/22	F/32
70mm	0.95m	0.94-0.96	0.94-0.96	0.93-0.97	0.92-0.98	0.91-0.99	0.90-1.01	0.88-1.03	0.85-1.07
	1.1m	1.09-1.11	1.08-1.12	1.07-1.13	1.06-1.14	1.05-1.16	1.03-1.19	1.00-1.22	0.97-1.29
	1.3m	1.28-1.32	1.27-1.33	1.26-1.34	1.24-1.36	1.22-1.39	1.19-1.43	1.16-1.49	1.10-1.60
	1.5m	1.47-1.53	1.46-1.54	1.44-1.56	1.42-1.59	1.39-1.63	1.35-1.69	1.30-1.77	1.23-1.94
	2m	1.94-2.06	1.92-2.09	1.89-2.12	1.85-2.18	1.80-2.25	1.72-2.39	1.64-2.58	1.52-2.99
	3m	2.86-3.15	2.82-3.21	2.75-3.31	2.65-3.46	2.54-3.67	2.38-4.10	2.21-4.76	1.98-5.55
	5m	4.61-5.47	4.48-5.67	4.30-5.99	4.05-6.55	3.79-7.42	3.42-9.55	3.06-14.65	2.61-148.10
	10m	8.49-12.18	8.03-13.29	7.44-15.32	6.71-19.88	5.98-31.76	5.07-∞	4.29-∞	2.61-148.10
	∞	48.51-∞	36.05-∞	26.33-∞	18.76-∞	13.82-∞	9.63-∞	7.08-∞	4.93-∞
	85mm	0.95m	F/2.8	F/4	F/5.6	F/8	F/11	F/16	F/22
1.1m		0.94-0.96	0.94-0.96	0.94-0.96	0.93-0.97	0.92-0.98	0.91-0.99	0.90-1.01	0.88-1.04
1.3m		1.09-1.11	1.09-1.11	1.08-1.12	1.07-1.13	1.06-1.14	1.05-1.16	1.03-1.19	1.00-1.23
1.5m		1.29-1.32	1.28-1.32	1.27-1.33	1.26-1.35	1.24-1.36	1.22-1.39	1.19-1.43	1.15-1.50
2m		1.48-1.52	1.47-1.53	1.46-1.54	1.44-1.56	1.42-1.59	1.39-1.63	1.35-1.69	1.29-1.79
3m		1.96-2.04	1.94-2.06	1.92-2.09	1.89-2.12	1.85-2.18	1.79-2.27	1.73-2.39	1.63-2.62
5m		2.90-3.11	2.86-3.15	2.81-3.21	2.74-3.32	2.65-3.45	2.52-3.71	2.38-4.07	2.18-4.88
10m		4.71-5.32	4.61-5.46	4.47-5.67	4.28-6.02	4.06-6.52	3.75-7.57	3.43-9.40	3.01-15.82
∞		8.87-11.46	8.51-12.14	8.03-13.29	7.40-15.47	6.75-19.50	5.89-34.54	5.11-49.80	4.19-∞
100mm		0.95m	F/2.8	F/4	F/5.6	F/8	F/11	F/16	F/22
	1.1m	0.95-0.96	0.94-0.96	0.94-0.96	0.94-0.97	0.93-0.97	0.92-0.98	0.91-0.99	0.89-1.02
	1.3m	1.09-1.11	1.09-1.11	1.09-1.12	1.08-1.12	1.07-1.13	1.06-1.15	1.04-1.16	1.02-1.19
	1.5m	1.29-1.31	1.28-1.32	1.28-1.32	1.27-1.33	1.26-1.35	1.24-1.37	1.22-1.39	1.19-1.44
	2m	1.48-1.52	1.48-1.52	1.47-1.53	1.46-1.55	1.44-1.56	1.42-1.59	1.42-1.59	1.34-1.70
	3m	1.97-2.03	1.96-2.04	1.94-2.06	1.92-2.09	1.89-2.12	1.85-2.19	1.79-2.26	1.71-2.41
	5m	2.93-3.08	2.90-3.11	2.86-3.15	2.81-3.22	2.74-3.31	2.64-3.48	2.53-3.70	2.36-4.14
	10m	4.79-5.23	4.72-5.32	4.61-5.46	4.46-5.69	4.29-6.00	4.03-6.60	3.76-7.50	3.38-9.73
	∞	9.17-11.00	8.99-11.44	8.51-12.14	8.00-13.37	7.44-15.31	6.67-20.21	5.93-32.88	5.01-∞
	135mm	0.95m	F/2.8	F/4	F/5.6	F/8	F/11	F/16	F/22
1.1m		0.95-0.95	0.95-0.95	0.94-0.96	0.94-0.96	0.94-0.96	0.93-0.97	0.93-0.98	0.91-0.99
1.3m		1.10-1.10	1.09-1.11	1.09-1.11	1.09-1.11	1.08-1.12	1.08-1.13	1.07-1.14	1.05-1.15
1.5m		1.29-1.31	1.29-1.31	1.29-1.31	1.28-1.32	1.28-1.33	1.28-1.34	1.26-1.34	1.23-1.38
2m		1.49-1.51	1.49-1.51	1.48-1.52	1.47-1.54	1.47-1.54	1.45-1.55	1.43-1.57	1.41-1.61
3m		1.98-2.02	1.98-2.02	1.97-2.03	1.95-2.05	1.94-2.07	1.91-2.10	1.88-2.14	1.83-2.21
5m		2.96-3.04	2.94-3.06	2.92-3.08	2.89-3.12	2.85-3.17	2.79-3.25	2.72-3.35	2.60-3.54
10m		4.88-5.12	4.84-5.17	4.78-5.25	4.69-5.36	4.58-5.31	4.41-5.78	4.22-6.13	3.95-5.84
∞		9.52-10.63	9.35-10.75	9.11-11.08	8.78-11.62	8.39-12.37	7.82-13.87	7.24-16.23	6.43-22.66
200mm		0.95m	F/2.8	F/4	F/5.6	F/8	F/11	F/16	F/22
	1.1m	0.95-0.95	0.95-0.95	0.95-0.95	0.95-0.96	0.94-0.96	0.94-0.96	0.94-0.97	0.93-0.97
	1.3m	1.10-1.10	1.10-1.10	1.10-1.10	1.09-1.11	1.09-1.11	1.09-1.11	1.09-1.11	1.07-1.13
	1.5m	1.30-1.30	1.30-1.30	1.29-1.31	1.29-1.31	1.29-1.31	1.28-1.32	1.27-1.33	1.26-1.34
	2m	1.50-1.50	1.49-1.51	1.49-1.51	1.49-1.51	1.48-1.52	1.47-1.53	1.47-1.53	1.45-1.55
	3m	1.99-2.01	1.99-2.01	1.98-2.02	1.98-2.03	1.97-2.03	1.95-2.05	1.94-2.07	1.91-2.10
	5m	2.98-3.02	2.97-3.03	2.96-3.04	2.94-3.06	2.92-3.08	2.89-3.12	2.85-3.17	2.79-3.25
	10m	4.94-5.06	4.92-5.08	4.89-5.12	4.84-5.17	4.78-5.24	4.69-5.36	4.58-5.31	4.41-5.76
	∞	9.76-10.25	9.67-10.35	9.54-10.50	9.36-10.74	9.14-11.04	8.80-11.59	8.42-12.32	7.85-13.77

# NOMENCLATURE

1. Lens hood
2. Hood attaching alignment mark
3. Hood attached indicator
4. Filter ring
5. Hood attaching index
6. Focusing ring / AF-MF selector
7. AF/MF selector index
8. Distance index
9. Distance scale
10. Zooming ring
11. Focal length scale
12. Zoom index
13. Tripod mount
14. Tripod mount index
15. Locking screw
16. Vertical index
17. Horizontal index
18. Lens attachment mark
19. Lens mount/Lens mount contacts

# SPECIFICATIONS

	<b>A001E</b>
Focal Length	70-200mm
Maximum Aperture	F/2.8
Angle of View	34 21'-12 21'
Lens Construction	13/18
Minimum Focus Distance	0.95m
Filter Size	77mm
Length	196.7mm
Diameter	89.5mm
Weight (without tripod mount)	1,150g
Weight (tripod mount)	175g
Hood	HA001

\* Features and cosmetic designs of lenses listed in this owner's manual may be revised without notice.

# ATTACHING AND REMOVING THE LENS

## How to mount the lens

Remove the rear cap of the lens. Align the lens attachment mark on the lens barrel with its counterpart on the camera mount and insert the lens. Rotate the lens clockwise until it click-locks

## How to detach the lens

Pressing the lens release button on the camera down, turn the lens counter-clockwise and lift the lens off from the camera's lens mount.

\*For further details, please read the instruction manual of your camera.

# FOCUSING (Autofocus)

Push the focusing ring / AF-MF selector forward to switch to AF mode. Press the shutter button lightly while viewing through the camera's viewfinder. The lens focuses automatically. An in-focus mark will light when the lens focuses on the main subject sharply. Press the shutter button further to photograph.

\* When set on AF mode, interfering with the focusing ring / AF-MF selector may cause serious damage to the lens mechanism.

\* Make sure you can see the letters "AF" on the focusing ring/AF-MF selector.

\*For further details, please read the instruction manual of your camera.

# FOCUSING (Manual Focus)

Pull the focusing ring / AF-MF selector back toward the camera to switch to MF mode. Focus by manually rotating the focusing ring / AF-MF selector while viewing through the camera's viewfinder. The main subject in the viewfinder will be sharp when the lens is focused correctly.

**\*Make sure the blue ring surrounding the focus ring is visible and the AF/MF selector covers the "M" mark.**

\* Even when in MF mode, turning the focusing ring while pressing the shutter button halfway, the focus aid function lamp lights up when the picture is in focus.

\* At infinity, make sure the image in the viewfinder appears sharp. The infinity position is made with certain allowances to insure proper focus under a variety of conditions.

\* For further details, please read the instruction manual of your camera.

# ZOOMING

Rotate zooming ring (9) of the lens while viewing through the camera's viewfinder and compose your image at the chosen focal length.

# LENS APERTURE AND AE MODE

Please follow the instruction manual of your camera.

# LENS HOOD

A bayonet-type lens hood is provided as standard equipment. We recommend shooting with the hood attached whenever possible as the lens hood eliminates stray light, which is harmful to the picture. However, please be aware of the precautions stated in the next section when your camera is equipped with a built in flash.

## Attaching the Lens Hood

Align Hood attaching alignment mark (2) on the hood with the corresponding index mark (5) on the lens. Press the hood lightly onto the hood attaching bayonet ring and then rotate it clockwise to secure. The lens hood will be secure when the mark "TAMRON O" is at the top.

\*Improper attachment of the hood may cause large shadowed areas in your pictures.

## Stowing lens hood on the lens

Reverse the lens hood. Point the lens toward the opening, then align the hood attaching index on the lens with the hood attaching indicator, "TAMRON O", on the hood. Turn the hood clockwise until the alignment mark is at the top to set it.

# TRIPOD MOUNT

A001 comes with a tripod mount. When using a tripod, mount the lens to it using the tripod mount.

## Changing the position of the camera horizontally and vertically

1. Turn the locking screw (15) on the tripod mount counter-clockwise to loosen.
2. Line up the tripod mount index (14) with the vertical index (16) or with the horizontal index (17).
3. Turn the locking screw (15) on the tripod mount clockwise to secure.

## Removing the tripod mount

1. Turn the locking screw on the tripod mount counter-clockwise.
2. The tripod mount will loosen and can be removed from the lens.

## Installing the tripod mount

1. Loosen the tripod mount (13) and attach it to the lens barrel.
2. Tighten the tripod mount (13) and turn the locking screw (15) clockwise to secure.

\*When attaching or removing the tripod mount, be careful not to drop the camera and/or the lens.

\*Be cautious when carrying the lens while lens is attached to the tripod mount.

## PRECAUTIONS IN SHOOTING

-The optical design for Di takes into consideration the various features of digital single reflex cameras. However, due to the configuration of the digital single reflex cameras, even when auto focus accuracy is within specifications, the focal point may be a little forward or behind the optimum point when shooting with autofocus under some conditions.

-The lens employs an internal focusing (IF) system. Because of the characteristics of this optical design, the angles of view at distances other than infinity are wider than that of the lenses applying an ordinary focusing system.

-When the built-in-flash on the camera is used, adverse photographic phenomena such as corner illumination fall-off or vignetting at the bottom part of the image may be observed, especially in wide angle ranges. This is due to the inherent limitation of the coverage of the built-in-flash, and/or the relative position of the flash to the edge of the lens barrel which causes shadows on the image. It is strongly recommended to use a suitable separate flash unit provided by the camera manufacturer for all flash photography. For further details, please read the "built-in-flash" article on the instruction manual of your camera.

-When using the lens in telephoto focal range, please be cautious with the camera shake. To avoid camera shake, for the digital cameras, use an ISO setting of higher numbers and for the film cameras, use the film with high ISO numbers to obtain higher shutter speeds. Using a tripod or monopod is also effective.

When hand-holding the camera to take pictures, stand still opening your legs slightly apart, hold your elbows in firmly against your chest, and hold the camera firmly against your face. If possible, lean against something to steady yourself or place the camera on something to secure the hold. Especially when hand-holding your camera, you will be steadier if you hold your breath while you press the shutter button gently and firmly.

-When set on AF mode, interfering with the focusing ring may cause serious damage to the lens mechanism.

-Certain camera models may indicate the maximum and minimum aperture values of the lens in approximate numbers. This is inherent to the design of the camera and not an indication of error.

-Please be aware that there is no infrared index line on any models listed in this owner's manual, and therefore, practically no black-and-white infrared film can be used with these lenses.

# TO ENSURE LONG-TERM SATISFACTION

-Avoid touching the glass element surface. Use photographic lens cloths or blowers to remove dust from the lens element surface. When not using the lens, always place a lens cap on it for protection.

-Use a lens cleaning tissue or lint cloth with a drop of cleaning solution to remove fingerprints or dirt on the glass lens surface with a rotary motion from the center to the edge. Use a silicone cloth to clean your lens barrel only.

-Mildew is an enemy of your lens. Clean the lens after shooting near water or in any humid place. Store your lens in a clean, cool, dry place. When storing the lens in a lens case, store it with commercially available drying agents such as silicagel, and change the agent occasionally. If you find mildew on your lens, consult an authorized repair shop or nearby photographic store.

-Do not touch the lens-camera interface contacts since dust, dirt and/or stains may cause a contact failure between the lens and camera.

-When using your equipment [camera(s) and lens(es)] in an environment where the temperature changes from one extreme to the other, make sure to put your equipment temporarily in a case or plastic bag for a length of time in order for the equipment to go through a gradual temperature shift. This will reduce potential equipment trouble.