

RX1HS

Dye-sublimation printer

DNP
Photo Imaging

The business kick-starter for high impact printing!

RX1HS is the cost effective and easy-to-use solution for integrated kiosks and photo professionals. All of DNP's dye-sublimation expertise in an affordable printer with economic media.

Designed for on-site event photography use, the printer is able to output 700 photos sized 4x6" in a single run. Reliable and made for tough assignments, RX1HS high print capacity and compact size will impress you.

A true workhorse!

2 YEAR
WARRANTY

6
inch



LOW INVESTMENT

HIGH PRINT CAPACITY

ECONOMIC MEDIA

HIGH SPEED

MATTE & GLOSSY FINISH

PERFORATED MEDIA

GET A TRULY ECONOMIC SOLUTION

- ▶ **Low initial investment**, with no sacrifice on functionality or quality
- ▶ **Economic photo consumables** ensuring a standard printing quality
- ▶ **Energy efficient** with low power consumption
- ▶ **Minimal consumables exchange** ensures easy maintenance and long cycles before changing media

PRINT ANY SIZE YOU WANT

- ▶ 3.5x5" (9x13cm) Exclusive size
- ▶ 4x6" (10x15cm) ▶ **Square size:** 5x5" (13x13cm) ▶ **Photo strips:** 2x6" (5x15 cm)
- ▶ 5x7" (13x18cm) 6x6" (15x15cm)
- ▶ 6x8" (15x20cm)

BENEFIT FROM HIGH SPEED PRINTING⁽¹⁾

Print size	High speed mode in Glossy finish
4x6" (10x15 cm)	12.4 sec.
5x7" (13x18cm)	19.9 sec.
6x8" (15x20cm)	21.9 sec.

Consumables	Prints/box	Perforated media	Without back print
RX1HS_46	1400	✓	✓
RX1HS_68	700	✓	✓
RX1HS_57	800		

Compatible with DNP's range of software products:
Hot Folder Print and **Party Print**

SPECIFICATIONS

Print deck	Simplex
Print technology	Dye-Sublimation thermal transfer 3-color ribbon YMC + Overcoat
Product code	369717
Gradations	256 (8-bit) for each color
Resolution (dpi)	300x300 (high speed mode) 300x600 (high quality mode)
Possible connectivity	DST4, DST4 Lite, DSTMini, DT-T6mini, SL620II, SL620, WPS Pro
Buffer memory	64MB
Interface	USB 2.0
Approx. weight	14 kg
Footprint	0.11 m ²
Media loading	Front loading
Power consumption (printing)	AC 240V-100V, 50/60Hz 1.6A / 3.9A
Compatibilities	Printer Driver : PC / MAC

Specification is subject to change without prior notice.



DNP PHOTO IMAGING EUROPE
22, Avenue des Nations
Immeuble Raphaël
CS 51077 Villepinte
95948 ROISSY C.D.G. Cedex
FRANCE

Tel : +33 (0)1 49 38 65 50
Fax : +33 (0)1 49 89 00 81
www.dnpphoto.eu

ENJOY DURABLE PERFORMANCE

- ▶ Reliable technology proven on-site
- ▶ **2 year warranty** or 40K prints whichever comes first

PROPOSE INNOVATIVE MEDIA

- ▶ DNP's dye-sublimation quality
- ▶ Create a unique 4x4" social media print size and a tear-away 2x4" strip that can be used for a marketing message

▶ Perforated media



▶ 2 print finishes



CHOOSE A WORKHORSE

- ▶ **High throughput**
- ▶ Large print capacity
- ▶ **290 prints per hour (4x6")**, in high speed mode with glossy finish
- ▶ **20% faster than its predecessor RX1⁽¹⁾**



⁽¹⁾Actual printing speed varies depending on printing condition.

TECHNICAL DRAWING

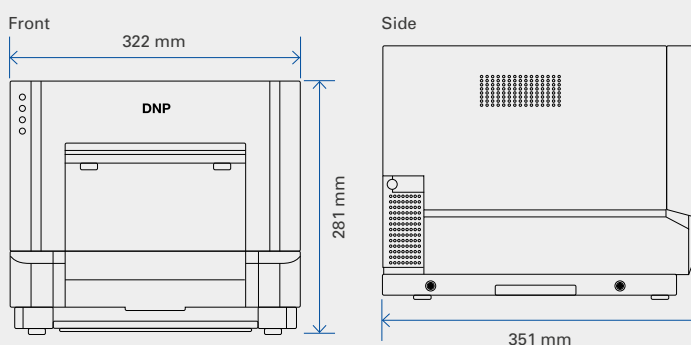

CONSUMABLES

Description	Product Code	Prints/box
4x6" (10x15 cm)	102114	1400
4x6" (10x15 cm) w/o backprint, forecast only	102111	1400
4x6" (10x15 cm), Perforated 4x3" and 4x2"	102114P	1400
5x7" (13x18cm)	102122	800
6x8" (15x20cm)	102115	700
6x8" (15x20cm) w/o backprint, forecast only	102113	700
6x8" (15x20cm), Perforated 3x(2x8)	102113P	700