

PENTAX

GPSユニット
GPS Unit

O-GPS1

使用説明書
Operating Manual

このたびは、ペンタックス・GPSユニットO-GPS1をお買い上げいただき誠にありがとうございます。

本機は、緯度、経度、高度、UTC（協定世界時）、方位情報をペンタックスデジタルカメラに記録するためのアクセサリです。

この使用説明書は、前半が日本語・後半が英語で構成されています。ご使用前に、この使用説明書をよくお読みのうえ、正しくお使いください。

Thank you for purchasing the PENTAX GPS Unit O-GPS1. This GPS unit is a camera accessory for PENTAX digital cameras to record location information, such as latitude, longitude, altitude, Coordinated Universal Time (UTC), and orientation.

This operating manual is divided in two parts: The first part is in Japanese and the second in English. Please read this operating manual carefully first for proper use.

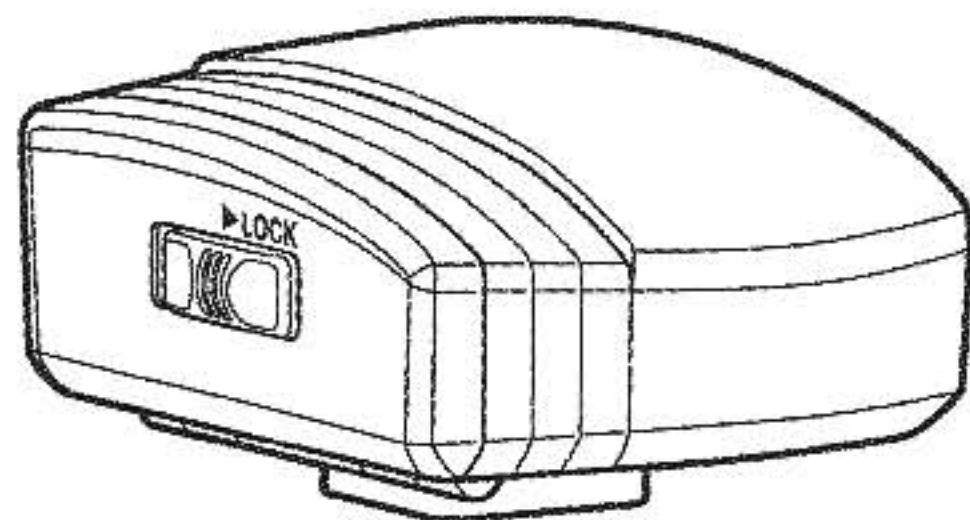

JA

EN

PENTAX

GPS Unit

O-GPS 1

Operating Manual

EN

Regarding a Trademark

PENTAX is a trademark of HOYA CORPORATION.

Illustrations and Terminology

In some illustrations in this manual, the PENTAX **K-5** is used as an example, and operations are explained on the assumption that the four-way controller is used to select a menu item and the **OK** button is used to determine the selection. Function names differ depending on the camera. For details, refer to the operating manual of your camera.

FOR THE SAFE USE OF YOUR GPS UNIT

Although we have carefully produced this GPS unit for safe operation, please take special note of the following:

WARNING

This symbol indicates that violating this item could cause serious personal injuries.

CAUTION

This symbol indicates that violating this item could cause minor or medium personal injuries, or loss of property.

WARNING

- Do not attempt to disassemble this GPS unit yourself.

CAUTION

- The following may lead to an explosion or fire.
 - Shorting a battery
 - Exposing a battery to flames
 - Disassembling a battery
 - Attempting to recharge a non-rechargeable battery

Precautions for Your GPS Unit



- Never use organic solvents such as thinner, alcohol or benzene to clean this GPS unit.

Contents

Names of Parts	2	Specifications	19
Features of the O-GPS1	3	Notes on the GPS Unit.....	20
Supported Cameras.....	3	Electronic Compass	20
Getting Started	4	Time	21
Inserting the Battery.....	4	Warranty Policy	22
Mounting the GPS Unit on the Camera	6		
Turning the GPS Unit On/Off	7		
Calibration.....	8		
Using the GPS Function	9		
Displaying the Electronic Compass	11		
Using the Simple Navigation Function	12		
Selecting the Destination and Displaying the Location Information	12		
Managing the Destination Information	12		
Using the ASTROTRACER Function	16		
Using Other Functions	18		
Setting the Positioning Interval	18		
Adjusting the Date and Time Automatically	18		

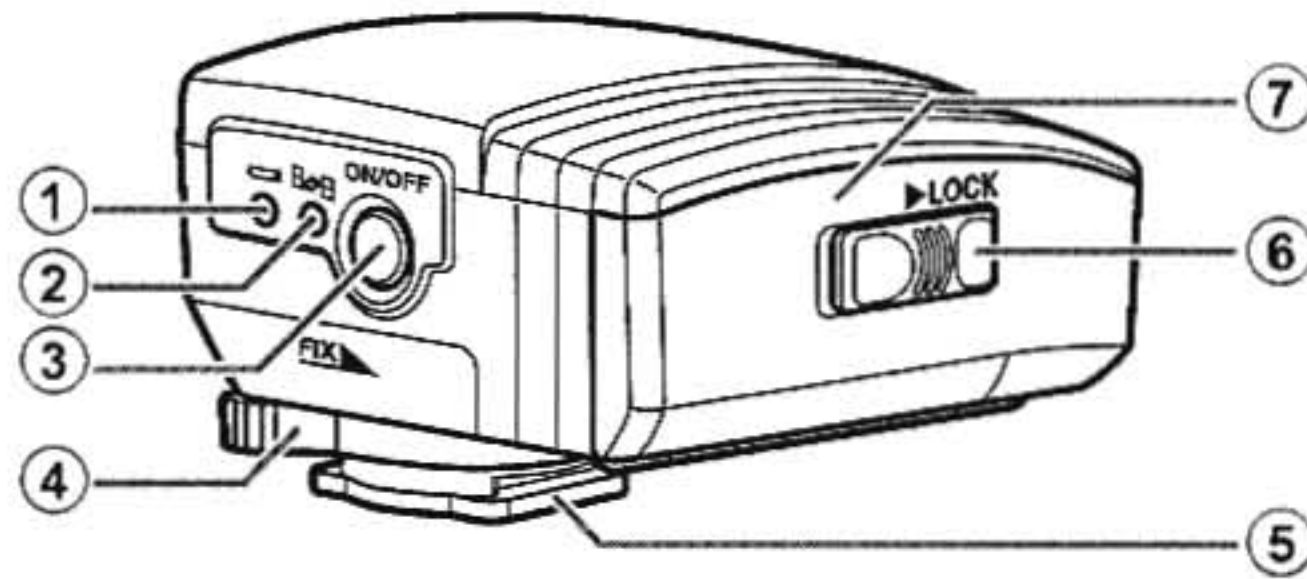
Names of Parts



- ①  lamp (orange: battery level)
- ②  lamp (blue: GPS positioning status)
- ③ Power button
- ④ Locking lever

- ⑤ Mounting foot
- ⑥ Battery chamber lock
- ⑦ Battery chamber cover

Features of the O-GPS1

- Information can be sent to the camera by attaching the O-GPS1 unit to the camera's hot shoe.
- Designed with dust-proofness and water-resistance in mind.
- Features an electronic compass.
- Features the Simple Navigation function, which shows the distance to the destination.
- Features the ASTROTRACER function (a built-in equatorial mount), which is convenient when taking pictures of stars.

■ Supported Cameras

The PENTAX **K-5**, **K-r**, and **645D** support this GPS unit (as of May 2011). Before using this unit with the above-mentioned three models, however, you need to update the firmware of your camera. The firmware supporting GPS can be downloaded from the following website:
<http://www.pentax.jp/japan/products/o-gps1/>
For details about the compatibility of cameras released in May 2011 or later, refer to the

operating manual of the camera or visit our website.



- When the firmware of your camera is updated to a version supporting this GPS unit, new items are added to the shooting menu and/or playback mode palette, and the order of items changes accordingly.
- This GPS unit and a flash cannot be used at the same time. When using this GPS unit, always attach it to the camera.
- While shooting with Live View, the Electronic Compass and Simple Navigation functions are disabled.
- The ASTROTRACER function cannot be used with the **645D**. For details about the compatibility of cameras released in May 2011 or later, refer to the operating manual of the camera or visit our website.
- The maximum trace duration with the ASTROTRACER function varies depending on the shooting conditions.

Getting Started

■ Inserting the Battery

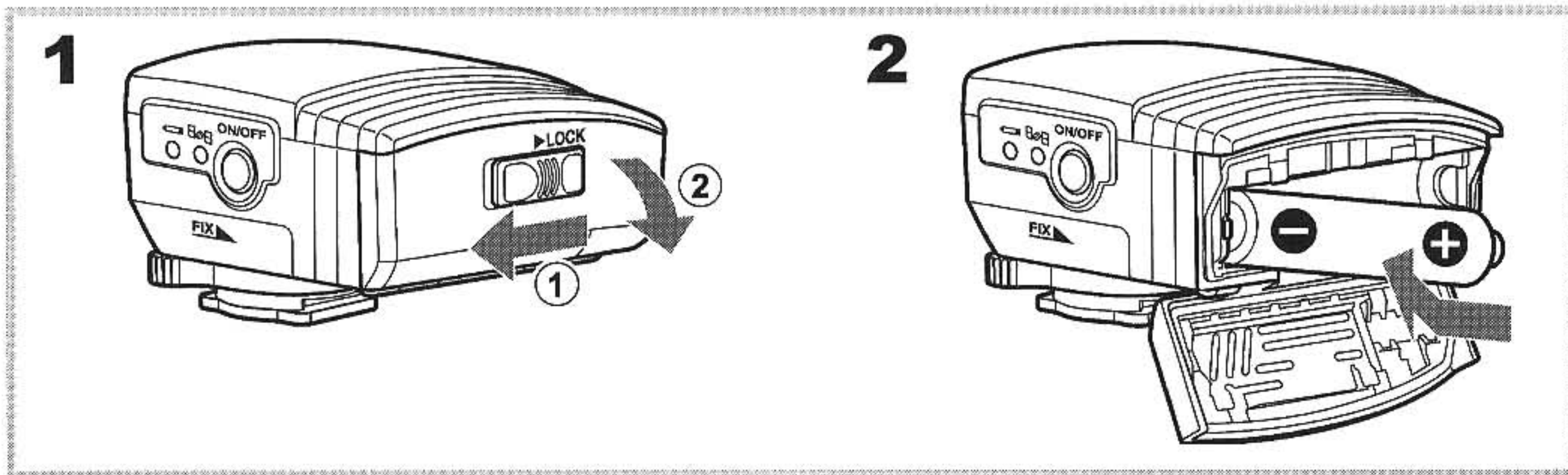

1 Slide the battery chamber lock to the direction indicated by arrow ① to unlock the battery chamber cover and open it to the direction indicated by arrow ②.

2 Insert an AAA battery making sure that the + and - markings match the illustration above.

3 Close the battery chamber cover and lock it.

Available Battery Types

The following batteries can be used.

- AAA alkaline battery
- AAA lithium battery
- AAA nickel-metal hydride battery

Caution

- If the  lamp does not light up or blink even when the power is turned on, the battery may be exhausted or not inserted correctly.
- Remove the battery if you are not going to use the GPS unit for a long time.
- Before replacing the battery, remove the GPS unit from the camera.

■ Mounting the GPS Unit on the Camera

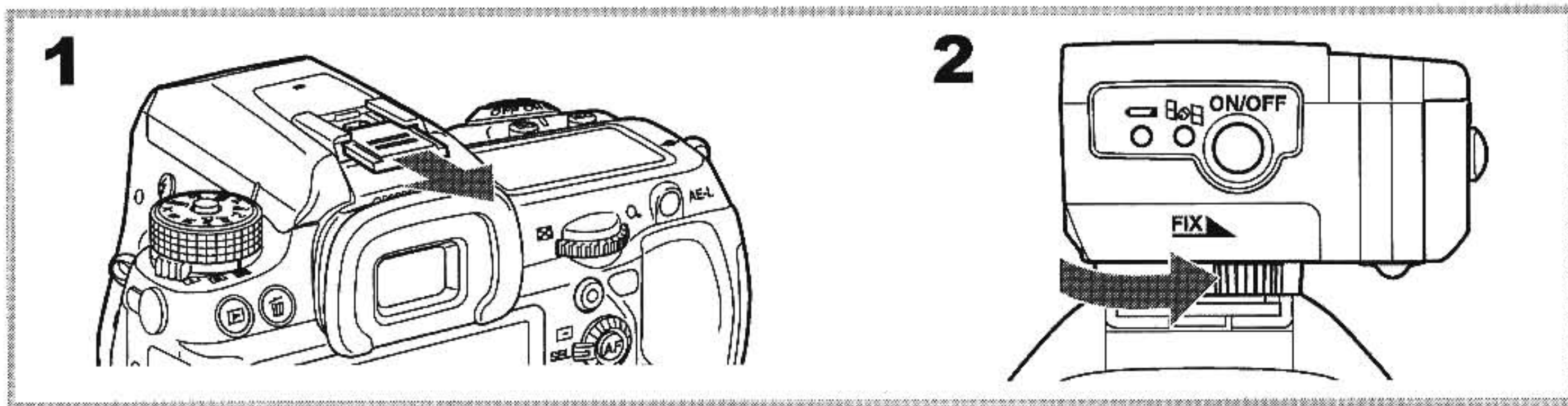

1 Remove the hot shoe cover of the camera. Keep the hot shoe cover safe and do not lose it.

2 Attach the GPS unit to the camera.

- ① Turn the locking lever of the GPS unit in the opposite direction to the arrow of "FIX →".
- ② Slide the mounting foot of the GPS unit into the camera's hot shoe from the back of the camera.
- ③ Turn the locking lever of the GPS unit in the direction of the arrow of "FIX →".



- When removing the GPS unit, be sure to first turn the locking lever in the opposite direction to the arrow of "FIX →" to loosen it. Otherwise, the hot shoe will be damaged.
- Do not pick up the camera by holding only the GPS unit. This could cause them to break.

■ Turning the GPS Unit On/Off

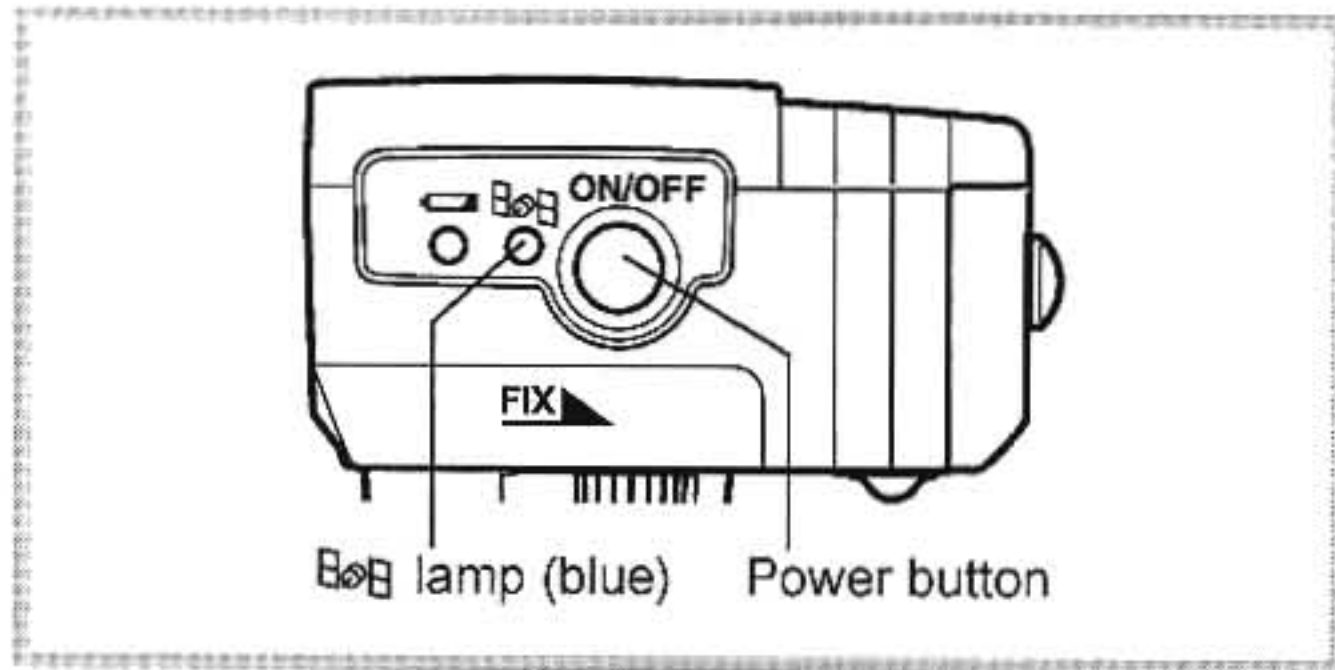



1 Press and hold the power button for one second.

The GPS unit turns on and the  lamp lights up or blinks (depending on the positioning status).

2 To turn the power off, press and hold the power button for one second again.



- When the battery is completely exhausted, the  lamp does not illuminate. When the battery is running low, the  lamp blinks as follows. In this condition, replace the battery with a new or fully-charged one.
 - When the exposure metering timer of the camera is off: Blinks every 3 seconds
 - When the exposure metering timer of the camera is on: Blinks every 2 seconds
- The functions which employ GPS (Electronic Compass, Simple Navigation and ASTROTRACER) are not enabled when the camera is turned off, or when the camera's Auto Power Off function is activated. If you want to use the Electronic Compass or Simple Navigation function continuously, cancel the camera's Auto Power Off function in advance.

■ Calibration

Calibration is the operation to get the electronic compass to work accurately. Always perform this before using the GPS unit.

As the Earth's magnetic field varies depending on the shooting location, precise calibration must also be performed at each location when shooting images of astronomical objects with the ASTROTRACER function.

- 1 Attach the GPS unit to the camera, and then turn on both the GPS unit and the camera.**
- 2 Select [Calibration] from [GPS] in the [📷 Rec. Mode] menu on the camera.**
- 3 Move the camera and perform the calibration.**

Hold the camera firmly and rotate the camera 180 degrees or more in each of three directions as shown on the right.

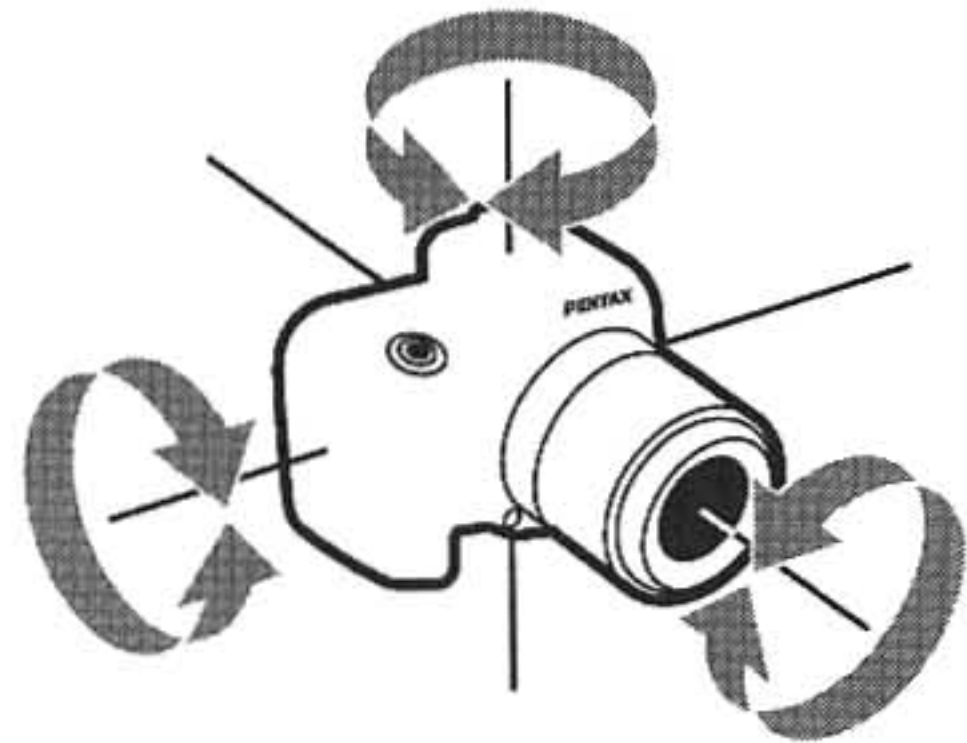

Caution

- Time allowed for calibration is one minute. If you cannot finish the calibration within a minute or the message [The operation could not be completed correctly] is displayed on the camera monitor, face the camera in a different direction and try the calibration again.
- Be careful not to drop the camera while performing the calibration.
- Always perform the calibration when a new or fully-charged battery is installed, or when the GPS unit is removed from the camera and then attached again.

Using the GPS Function

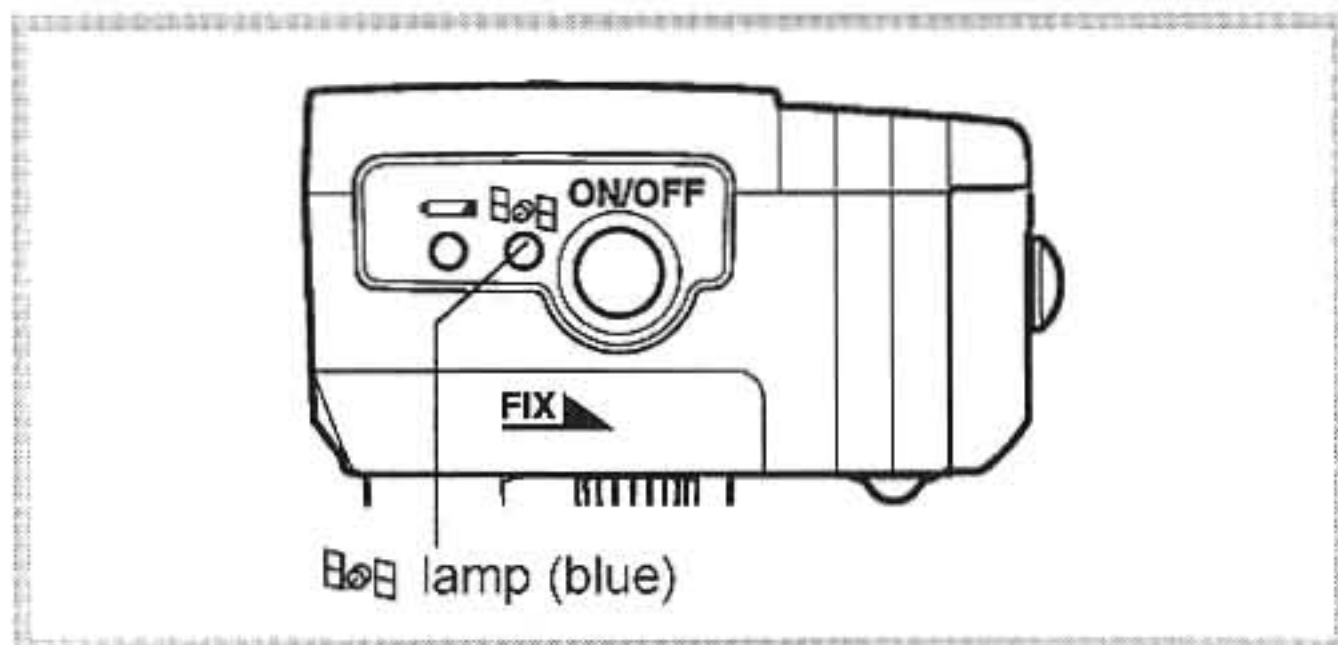



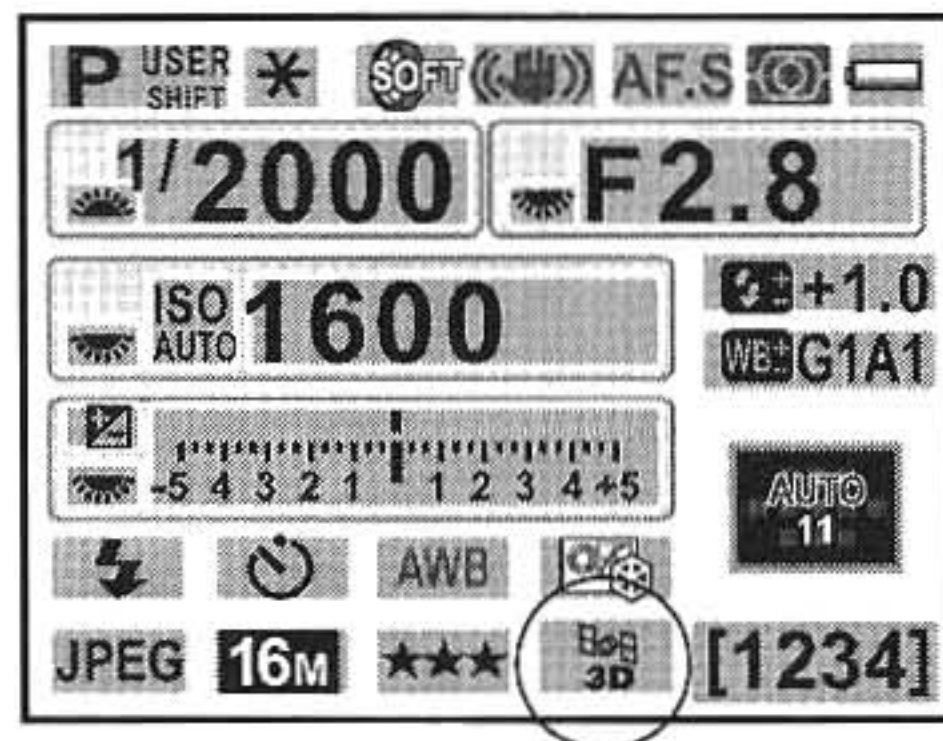

- 1 Attach the GPS unit to the camera, and then turn on both the GPS unit and the camera.

After the power is turned on, the  lamp blinks while positioning by GPS and then stays illuminated after the GPS positioning is carried out.

The GPS icon will be displayed on the status screen on the camera monitor.



lamp and GPS icons

 lamp	GPS icon	Status
Blinks	 (Red)	GPS data cannot be obtained.
Lights	 (Yellow)	Three satellites are detected and GPS data can be obtained; the GPS data is recorded to an image when shooting.
Lights	 (Green)	Four or more satellites are detected and more precise GPS data can be obtained; the GPS data is recorded to an image when shooting.

2 Take a picture.

The current location information will be recorded to the image.

* For the movies, GPS data cannot be recorded.

3 Play back the image and check the GPS data.

For details on how to play back images, refer to the operating manual of the camera.

■ Displaying the Electronic Compass

The electronic compass can be displayed on the camera monitor.

- 1 Select [Electronic Compass] from [GPS] in the [📷 Rec. Mode] menu on the camera.

The electronic compass appears on the camera monitor and the current latitude, longitude, altitude, direction*, and the Coordinated Universal Time (UTC) are displayed. If you rotate the camera to point the lens in a different direction, the face of the electronic compass turns.

* On the electronic compass of this GPS unit, 0° is based on True North, not Magnetic North. (180° is based on True South.)

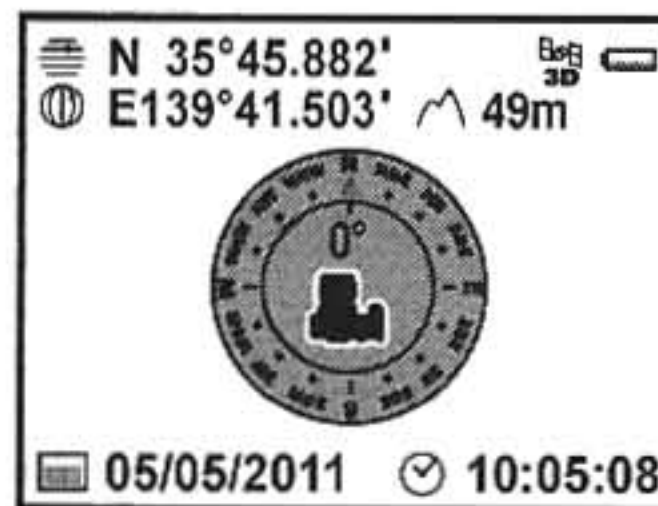

If you operate the camera (such as changing the shooting mode) while the electronic compass is displayed on the camera monitor, the camera stops displaying the electronic compass. Select [Electronic Compass] from [GPS] in the [📷 Rec. Mode] menu to display the electronic compass again.

Using the Simple Navigation Function

■ Selecting the Destination and Displaying the Location Information

Direction and distance to the destination based on the current location can be displayed.

- 1** Select [Simple Navigation] from [GPS] in the [📷 Rec. Mode] menu on the camera.
- 2** Select [Select Destination].
- 3** Select the desired destination.
- 4** Select [Navigation Start].
Direction (Δ mark on the compass face) and distance to the destination are displayed, based on the current location.



■ Managing the Destination Information

Destination information can be saved to or deleted from a memory card. The information saved on the memory card can also be loaded.

- 1** Select [Simple Navigation] from [GPS] in the [📷 Rec. Mode] menu on the camera.
- 2** Select [Destination Manager].

- 3** Select [Load from the card], [Save to the card], or [Delete destination].

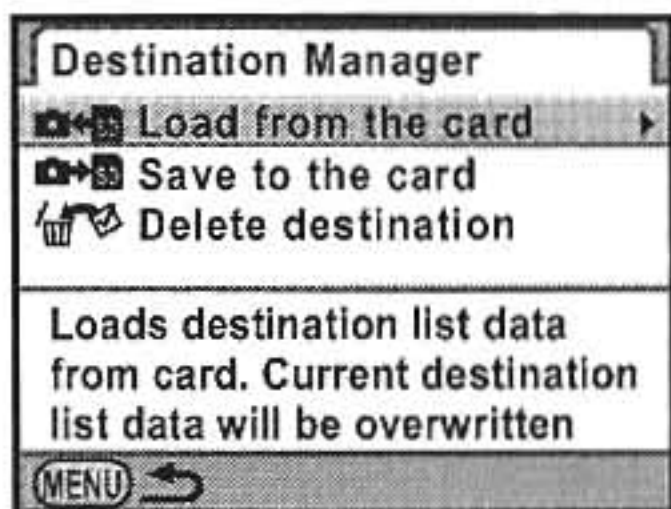

Loading data from the card/Saving data to the card

- 4** Select a file to save the destination list data.

To save the destination list data to the memory card, enter the name of the destination list file (Title Entry) first and save it.

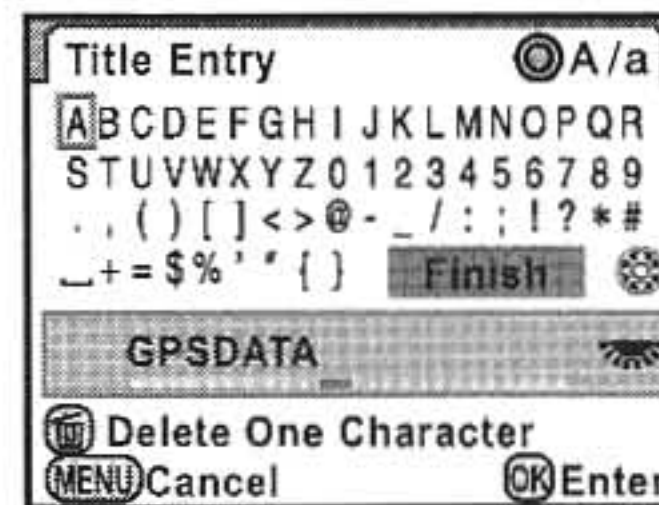
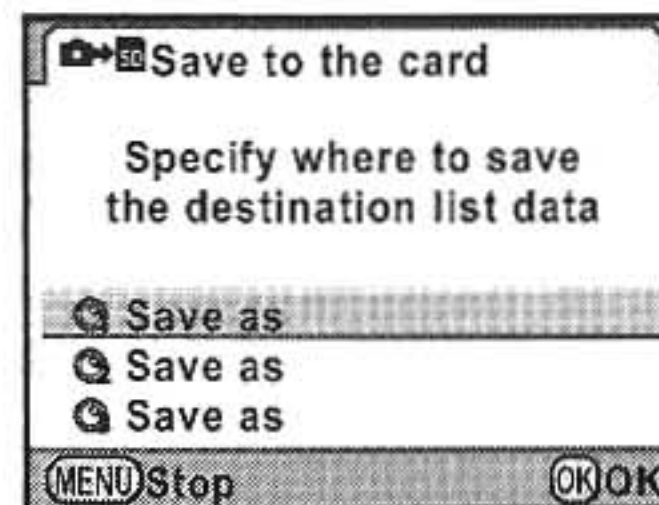

Deleting the destination data

4 Select destination(s) to be deleted.

Press the **OK** button to tick the checkbox .

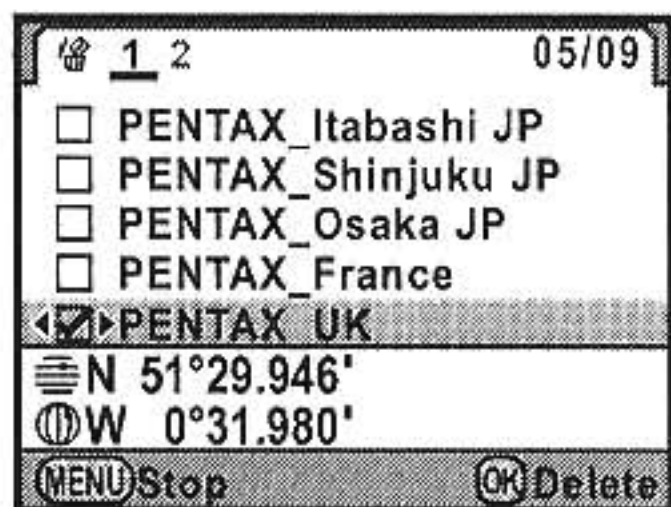

5 Press the **⌫** button.

6 Select [Select & Delete].

The selected destination(s) will be deleted.



- As the destination data of the factory default setting is deleted if overwritten, save it as necessary.
- To save the shooting location of the image with GPS information as a destination, play back the image and select [Save Destination] in the playback mode palette.

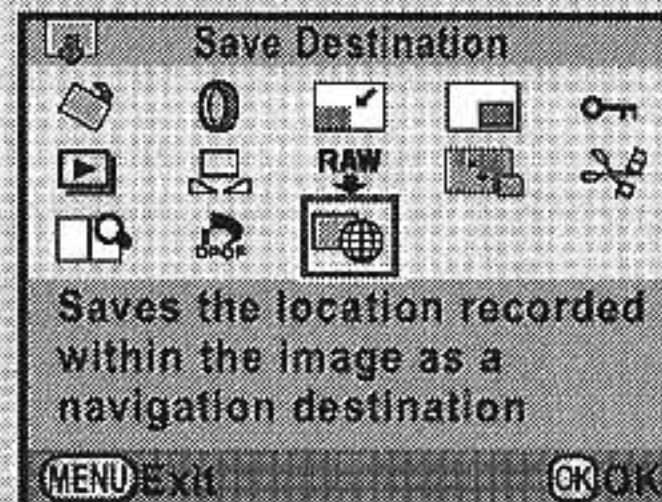

- When using the **645D**, be sure to insert an SD Memory Card into the SD2 slot (thumbnail images and location information are saved to the SD Memory Card inserted in the SD2 slot).



- If you operate the camera (such as changing the shooting mode) while using the Simple Navigation function, the camera stops displaying the location information. Select [Simple Navigation] from [GPS] in the [📷 Rec. Mode] menu and start the navigation to display the location information again.

Using the ASTROTRACER Function

When shooting images of astronomical objects with long exposure by using a camera with the Shake Reduction function, the ASTROTRACER function enables you to track them as the Earth rotates and make them look like stationary points of light with no trails in the images.

- 1 Set the exposure mode and the focus mode of the camera to Bulb and MF (Manual focus), respectively.**

Refer to the operating manual of the camera.

- 2 Select [ASTROTRACER (Bulb)] from [GPS] in the [Rec. Mode] menu on the camera.**

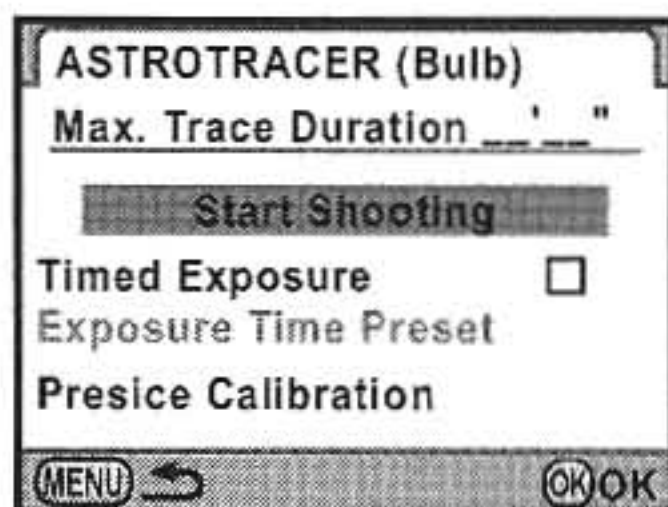

- 3 Select [Precise Calibration].**

Hold the camera firmly and rotate the camera 180 degrees or more in each of three directions as shown below.

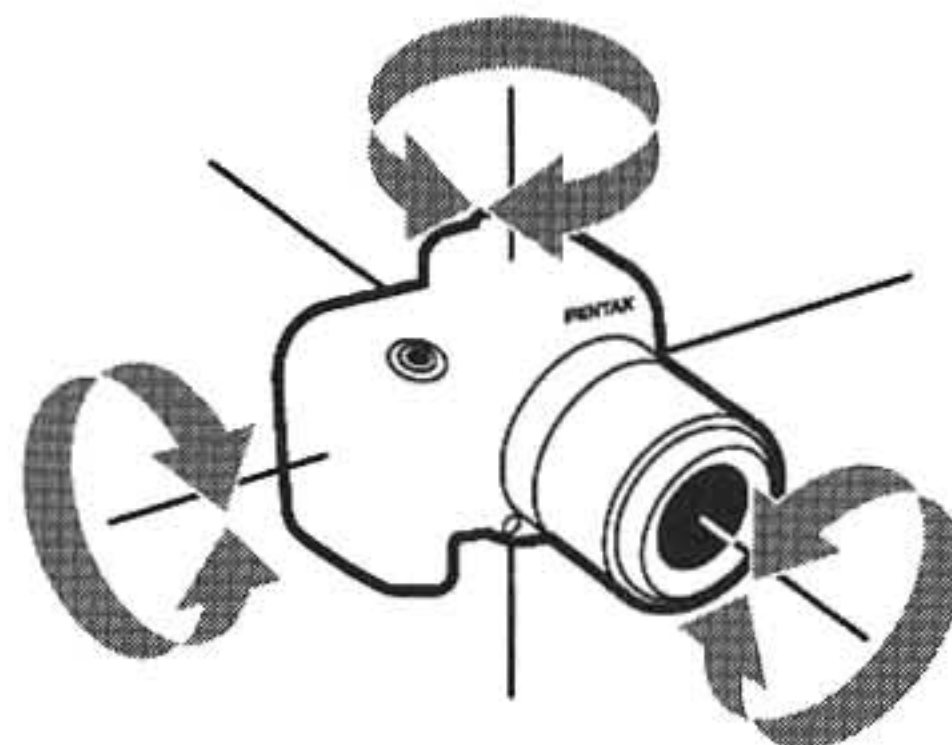

- 4 To set the exposure time using the timer, tick the checkbox for [Timed Exposure] and set the time in [Exposure Time Preset].**
Set the exposure time (minute/second).
- 5 Select [Start Shooting].**

6 Set the focus and press the shutter release button.

Shooting starts.

When shooting is finished, the ASTROTRACER setting screen is displayed again.



- When using the ASTROTRACER function, the shutter cannot be released and shooting will not start until the GPS positioning is carried out.
- The maximum trace duration varies depending on the focal length, shooting location, or direction that the camera faces to. You cannot set the exposure time longer than the maximum trace duration.
- When using a lens without focal length information, set the focal length of your lens with [Input Focal Length] in the [📷 Rec. Mode] menu before shooting images of astronomical objects.
- Always execute the precise calibration before shooting images of astronomical objects.
- When using the ASTROTRACER function, [Horizon Correction] and [Composition Adjust.] of the camera are not enabled.



- As the precise calibration performs high-accuracy calibration, it takes a while to complete.
- When shooting images of astronomical objects, you cannot use autofocus. Adjust the focus manually.

Using Other Functions

■ Setting the Positioning Interval

You can set the duration to receive the GPS data (duration to perform the positioning).

- 1 Select [Positioning Interval] from [GPS] in the [📷 Rec. Mode] menu on the camera.
- 2 Select [1min.], [3min.], [5min.], or [10min.].



- According to the [Positioning Interval] setting, metering operating time of the camera is extended automatically.
- When the GPS unit is on, [Meter Operating Time] in the [C Custom Setting] menu is displayed in grey and cannot be selected.

■ Adjusting the Date and Time Automatically

After turning the camera on, the date and time of the camera are updated according to the signal (2D or 3D) first received from the GPS unit.

- 1 Select [Auto Time Synch.] from [GPS] in the [📷 Rec. Mode] menu on the camera.
- 2 Tick the checkbox .

Specifications

Product name	PENTAX GPS Unit O-GPS1
Type	Clip-on GPS unit
Supported camera	K-5 , K-r , and 645D (as of May 2011)
Recorded information	Latitude, longitude, altitude, time (UTC), direction
Receiving function	Tracking channels: 50, supports SBAS (WAAS/EGNOS/MSAS)
Acquisition time	Cold-start: approx. 40 seconds, hot-start: approx. 5 seconds
Positioning interval	1 second
GPS accuracy	10 m RMS
Data format	NMEA-0183
Geodesics	World Geodetic System (WGS 84)
Electronic compass	Accuracy: $\pm 5^\circ$ (precise calibration), positioning interval: approx. 8 times, reference direction: True North
Dimensions	Approx. 49.0 mm (W) \times 33.0 mm (H) \times 59.5 mm (D)
Weight	Approx. 61 g (including alkaline battery), approx. 50 g (unit only)
Power source	AAA battery \times 1 (alkaline battery, nickel-metal hydride battery, or lithium battery)
Battery life	Continuous operating time: approx. 7 hours (normal temp.)/ 4 hours (0°) with alkaline battery approx. 7 hours (normal temp.)/ 5 hours (0°) with nickel-metal hydride battery approx. 12 hours (normal temp.)/ 9 hours (0°) with lithium battery

■ Notes on the GPS Unit

- Local geographic and atmospheric conditions may prevent or delay the reception of GPS data. This GPS unit may be unable to receive GPS data indoors, underground, or near large structures, trees, or other objects that block or reflect satellite signals.
- The positions of GPS satellites are continuously changing and this may prevent or delay the reception of GPS data at certain hours of the day.
- The presence of mobile phones or other devices that transmit frequencies close to those of GPS satellites, or magnetized high-voltage lines may also interfere with the reception of GPS data.
- Note that this GPS unit may take a while to reacquire a signal if it has not been used for an extended period or has been moved a great distance from where the GPS data was last received.
- Turn the power off in any place where, or on any occasion when the use of electronic

device is prohibited, such as while visiting a hospital, or taking off and landing of airplane.

- In some countries or regions, using GPS or collecting positioning data may be regulated. When you travel overseas, consult the embassy or your travel agency about using a camera with a GPS function or collecting the positioning log data.
- GPS data recorded in the image cannot be deleted. If you do not want to get the shooting location information before the public such as a website, etc., turn this GPS unit off before shooting.

■ Electronic Compass

- If you use this GPS unit near objects which generate a magnetic field such as magnets, or have magnetism such as iron, the electronic compass may not work properly.

■ Time

- The time recorded to images is Coordinated Universal Time (UTC). Please note, however, that when using the Electronic Compass or Simple Navigation function (when receiving GPS data), UTC is adjusted according to the time zone of the shooting location, and the adjusted time is displayed on the camera monitor.

Hereby, HOYA CORPORATION, declares that this GPS unit O-GPS1 is in compliance with the essential requirements and other relevant provisions of Directive 1999/5/EC. For a full version of the Declaration of Conformity (DoC), please refer to <http://www.pentax.jp/english/>.

Warranty Policy

All PENTAX camera accessories purchased through authorized bona fide photographic distribution channels are guaranteed against defects of material or workmanship for a period of twelve months from date of purchase. Service will be rendered, and defective parts will be replaced without cost to you within that period, provided the equipment does not show evidence of impact, sand or liquid damage, mishandling, tampering, battery or chemical corrosion, operation contrary to operating instructions, or modification by an unauthorized repair shop. The manufacturer or its authorized representatives shall not be liable for any repair or alterations except those made with its written consent and shall not be liable for damages from delay or loss of use or from other indirect or consequential damages of any kind, whether caused by defective material or workmanship or otherwise; and it is expressly agreed that the liability of the manufacturer or its representatives under all guarantees or warranties, whether expressed or implied, is strictly limited to the replacement of parts as herein before provided. No refunds will be made on repairs by non-authorized PENTAX service facilities.

Procedure During 12-month Warranty Period

Any PENTAX which proves defective during the 12-month warranty period should be returned to the dealer from whom you purchased the equipment or to the manufacturer. If there is no representative of the manufacturer in your country, send the equipment to the manufacturer, with postage prepaid. In this case, it will take a considerable length of time before the equipment can be returned to you owing to the complicated customs procedures required. If the equipment is covered by warranty, repairs will be made and parts replaced free of charge, and the equipment will be returned to you upon completion of servicing. If the equipment is not covered by warranty, regular charges of the manufacturer or of its representatives will apply. Shipping charges are to be borne by the owner. If your PENTAX was purchased outside of the country where you wish to have it serviced during the warranty period, regular handling and servicing fees may be charged by the manufacturer's representatives in that country. Notwithstanding this, your PENTAX returned to the manufacturer will be serviced free of charge according to this procedure and warranty policy.

In any case, however, shipping charges and customs clearance fees are to be borne by the sender. To prove the date of your purchase when required, please keep the receipts or bills covering the purchase of your equipment for at least a year. Before sending your equipment for servicing, please make sure that you are sending it to the manufacturer's authorized representatives or their approved repair shops, unless you are sending it directly to the manufacturer. Always obtain a quotation for the service charge, and only after you accept the quoted service charge, instruct the service station to proceed with the servicing.

- This warranty policy does not affect the customer's statutory rights.
- The local warranty policies available from PENTAX distributors in some countries can supersede this warranty policy. Therefore, we recommend that you review the warranty card supplied with your product at the time of purchase, or contact the PENTAX distributor in your country for more information and to receive a copy of the warranty policy.

For customers in USA

STATEMENT OF FCC COMPLIANCE

This device complies with Part 15 of the FCC Rules. Operation is subject to the following two conditions: (1) This device may not cause harmful interference, and (2) this device must accept any interference received, including interference that may cause undesired operation.

Changes or modifications not approved by the party responsible for compliance could void the user's authority to operate the equipment.

This equipment has been tested and found to comply with the limits for a Class B digital device, pursuant to part 15 of the FCC Rules.

These limits are designed to provide reasonable protection against harmful interference in a residential installation. This equipment generates, uses and can radiate radio frequency energy and, if not installed and used in accordance with the instructions, may cause harmful interference to radio communications. However, there is no guarantee that interference will not occur in a particular installation.

If this equipment does cause harmful interference to radio or television reception, which can be determined by turning the equipment off and on, the user is encouraged to try to correct the interference by one or more of the following measures:

- Reorient or relocate the receiving antenna.
 - Increase the separation between the equipment and receiver.
 - Connect the equipment into an outlet on a circuit different from that to which the receiver is connected.
- * Consult the dealer or an experienced radio/TV technician for help.

For customers in Canada

This Class B digital apparatus complies with Canadian ICES-003.

Pour les utilisateurs au Canada

Cet appareil numérique de la classe B est conforme à la norme NMB-003 du Canada.

HOYA CORPORATION	2-35-7, Maeno-cho, Itabashi-ku, Tokyo 174-8639, JAPAN
PENTAX Imaging Systems Division	(http://www.pentax.jp)
PENTAX Europe Imaging Systems S.A.S. (European Headquarters)	112 Quai de Bezons, B.P. 204, 95106 Argenteuil Cedex, FRANCE (HQ - http://www.pentax.eu) (France - http://www.pentax.fr)
PENTAX Imaging Systems GmbH	Julius-Vosseler-Strasse 104, 22527 Hamburg, GERMANY
PENTAX Imaging Systems Limited	PENTAX House, Heron Drive, Langley, Slough, Berks SL3 8PN, U.K. (http://www.pentax.co.uk)
PENTAX Imaging Company	(Headquarters)
A Division of PENTAX of America, Inc.	600 12th Street, Suite 300 Golden, Colorado 80401, U.S.A. (PENTAX Service Department) 250 North 54th Street Chandler, Arizona 85226, U.S.A. (http://www.pentaximaging.com)
PENTAX Canada Inc.	1770 Argentia Road Mississauga, Ontario L5N 3S7, CANADA (http://www.pentax.ca)
PENTAX Trading (SHANGHAI) Limited	23D, Jun Yao International Plaza, 789 Zhaojiabang Road, Xu Hui District, Shanghai, 200032 CHINA (http://www.pentax.com.cn)

<http://www.pentax.jp/english>

- Specifications and external dimensions are subject to change without notice.



The CE Mark is a Directive conformity mark of the European Union.

Notification of Change in Company Name

HOYA CORPORATION PENTAX Imaging Systems Division will officially be renamed PENTAX RICOH IMAGING COMPANY, LTD. on October 1, 2011. We will continue to market a fine line of products under the familiar PENTAX brand to satisfy your demands and requirements.

We thank you for your continued support and patronage to PENTAX RICOH IMAGING COMPANY, LTD. and our PENTAX-brand products.

Announce du changement de nom de notre société

La société HOYA CORPORATION PENTAX Imaging Systems Division prendra le nom de PENTAX RICOH IMAGING COMPANY, LTD. à partir du 1er octobre 2011.

Suite à notre rachat par la société RICOH, et afin de satisfaire les possesseurs d'appareils photo PENTAX et conserver la notoriété de notre marque depuis presque un siècle, nos produits conserveront le nom PENTAX.

Nous tenons à vous remercier par avance pour votre fidélité et espérons que vous continuerez à faire confiance à PENTAX RICOH IMAGING COMPANY, LTD. et aux produits PENTAX.